

Rev.	Amendments	Date	Made By	Chk'd By

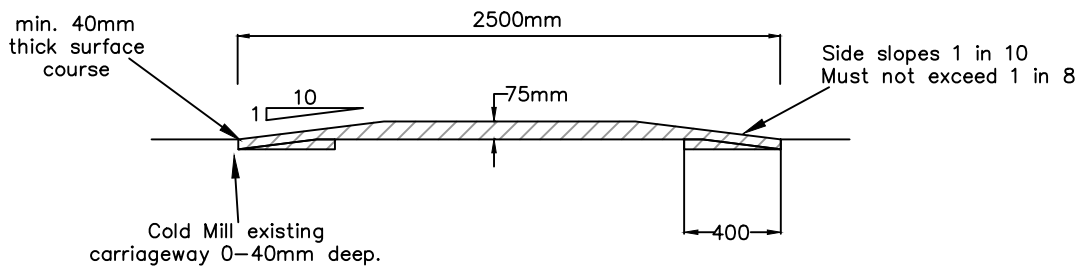

SECTION A-A

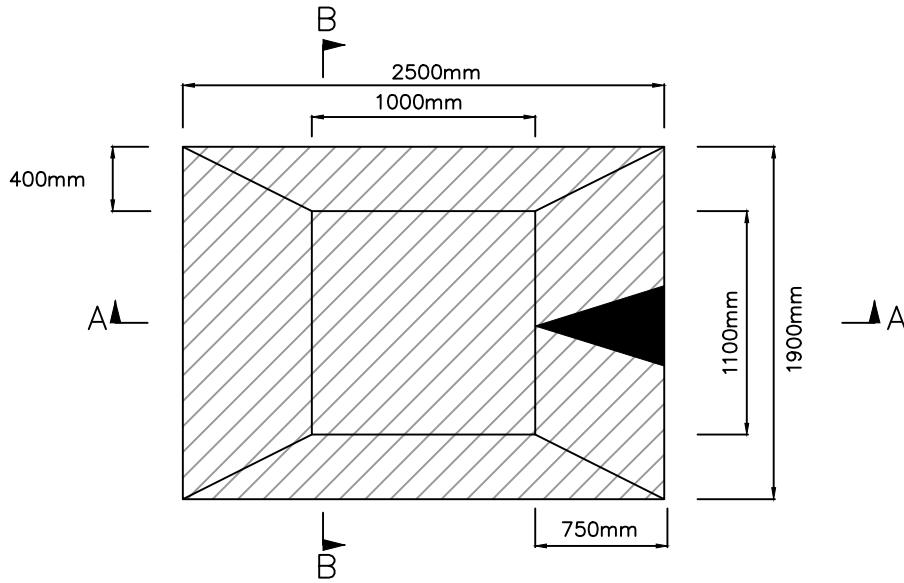
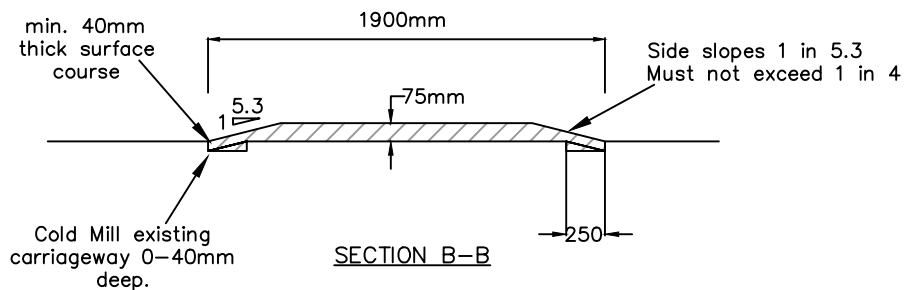

SECTION B-B

NOTES

1. The existing carriageway surface must be sprayed with tack coat (Class C40B4) cationic emulsion to BS EN 13808 at a rate of 0.5 litres/m².
2. The vertical face of the saw cut joint shall be treated with either, hot bituminous binder with penetration no less than 40/60 pen, or hot elastomeric polymer modified bituminous binder complying with BS EN 14023 with penetration no less than 40 pen.
3. Do not scale, use dimensioned figures only.
4. Road markings to be in accordance with current Traffic Signs Regulations and General Directions
5. Construction Tolerances will be :- Height and Levels ±10mm
Plan Dimensions ±50mm

SPEED CUSHION (CONSTRUCTION)

COMMON STANDARDS FOR WALES
HIGHWAY DESIGN GUIDE

Drawn	MT
Checked	SZ
Date	Feb '20
Scale	N.T.S.
Drg. No.	414
Rev.	