

Rev.	Amendments	Date	Made By	Chk'd By

Heavy duty grating and frame, single piece, hinged, non-rock, kerb side opening Class D400 to BS EN 124 and Kitemarked, minimum flange thickness of 75mm. The clear opening shall be 370 x 430 and a clear waterway area of 980cm as per the Watershed D400 or equivalent alternative to be agreed prior to use. Cover shall be set 5mm below finished road level.

Class 'B' engineering brick 225mm thick to BS EN 771 or concrete bricks to BS EN 771 having a crushing strength of not less than 40N/mm²

Mortar haunching to gully frame

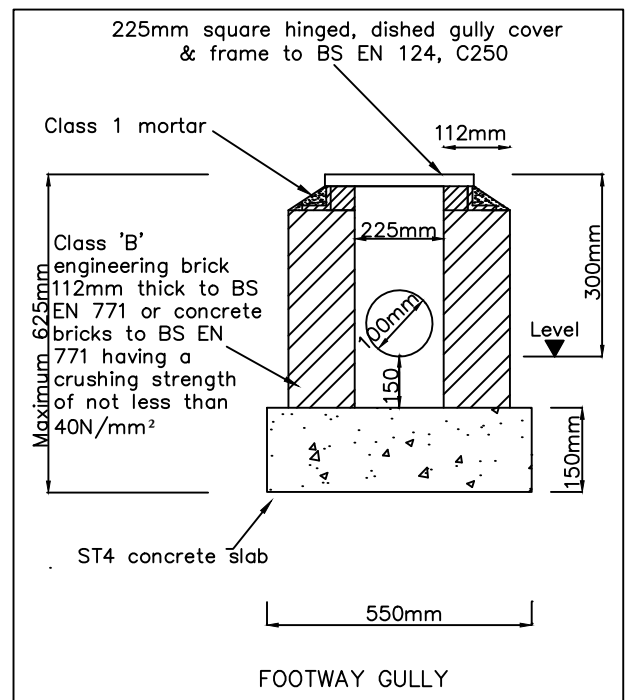
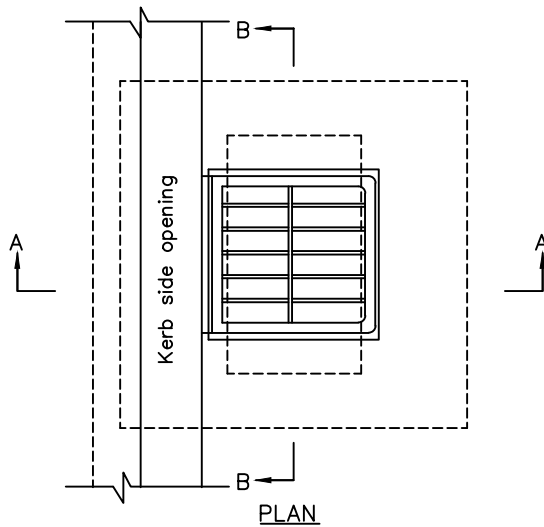
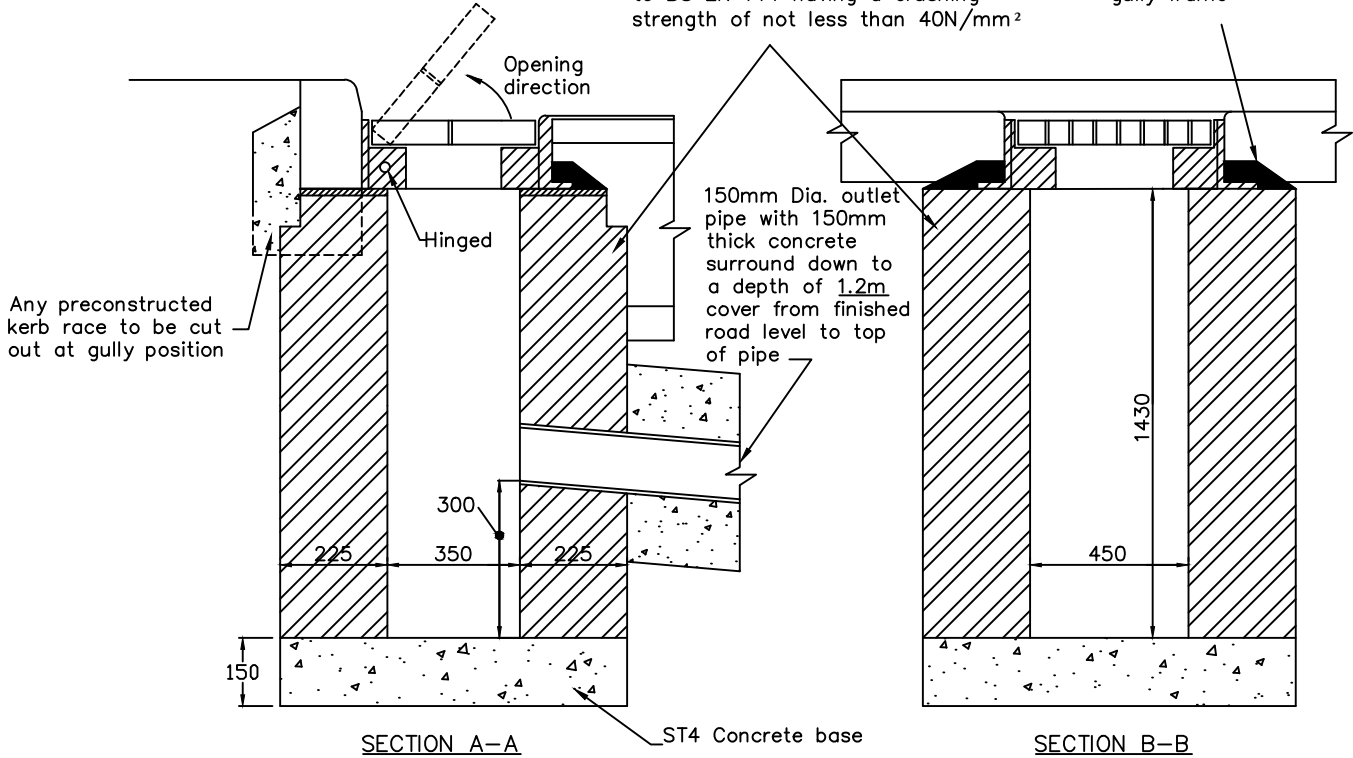

NOTES

1. All dimensions are in millimetres unless otherwise stated.
2. Concrete gully pots should always be used in the first instance. Brick gullies should only be used where space will not allow the use of a concrete gully pot.
3. Footway gullies, if the footway is likely to be trafficked, a road gully with a suitable footway grating will need to be provided.

BRICK ROAD GULLY AND FOOTWAY GULLY

COMMON STANDARDS FOR WALES HIGHWAY DESIGN GUIDE

Drawn	MT
Checked	SZ
Date	Feb '20
Scale	N.T.S.
Drng. No.	511
Rev.	