

Rev.	Amendments	Date	Made By	Chk'd By

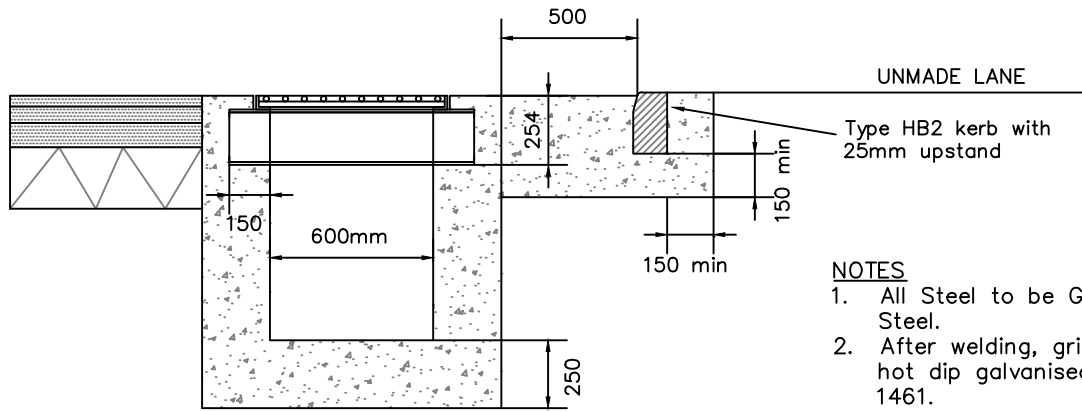

Section B-B

NOTES

1. All Steel to be Grade 43 Mild Steel.
2. After welding, grids are to be hot dip galvanised to BS EN ISO 1461.
3. Welds are to have a leg length of 10mm, a throat thickness of 7mm & a permissible load of 0.8kN/mm run at a load of 115 N/mm².
4. Surface finish of concrete is to be F1 on unexposed faces and F2 on exposed faces.
5. All dimensions are in millimetres unless otherwise stated.

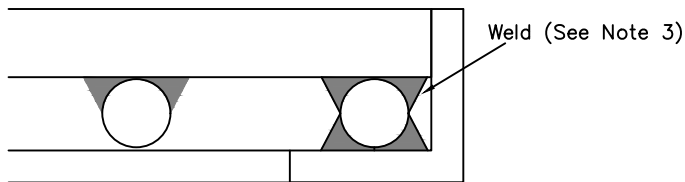

Weld Detail

Plan of Grid

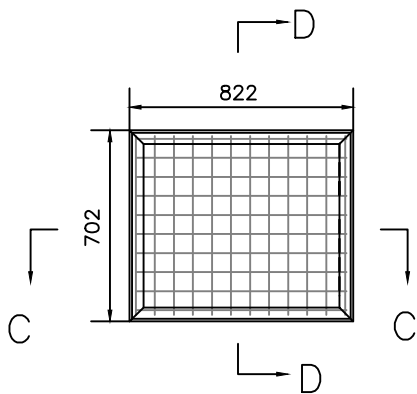

Section C-C

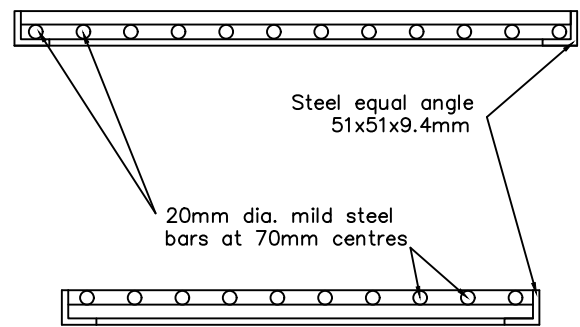

Section D-D

SILT / GRAVEL TRAP – GRID

COMMON STANDARDS FOR WALES
HIGHWAY DESIGN GUIDE

Drawn	MT
Checked	SZ
Date	Feb '20
Scale	N.T.S.
Drg. No.	520
Rev.	